

M-6072 6

CABLE DIA.  
.375 MIN.  
[9.53]  
1.220 MAX.  
[30.98]

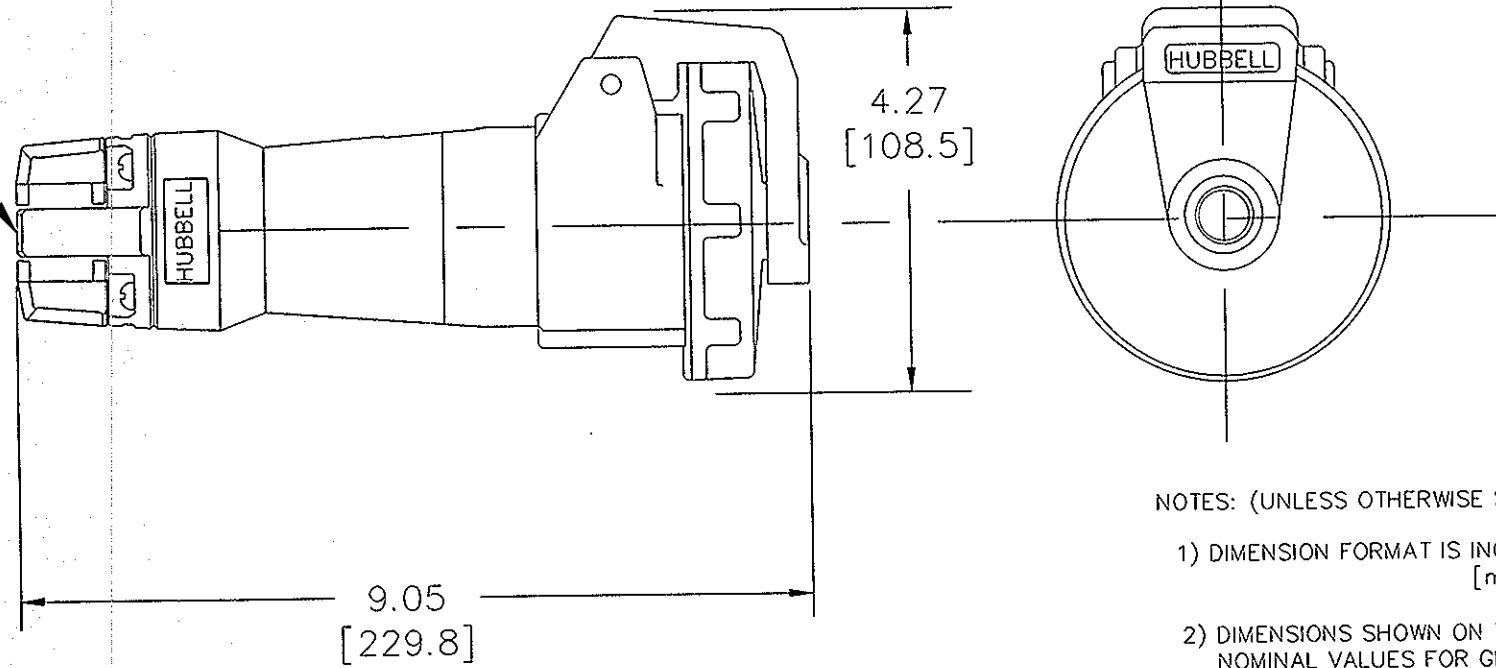

NOTES: (UNLESS OTHERWISE SPECIFIED)

1) DIMENSION FORMAT IS INCHES  
[mm]

2) DIMENSIONS SHOWN ON THIS DRAWING ARE  
NOMINAL VALUES FOR GENERAL USE ONLY  
ACTUAL PART TOLERANCES MUST BE  
OBTAINED FROM HUBBELL ENGINEERING.

LIST OF PARTS		
DESCRIPTION	MATERIAL	FINISH
HOUSING	SEE TABLE	
INTERIOR	THERMOSET	
SLEEVES	BRASS	
PH & NEUT. SPR.	STAIN. STEEL	
GRD. INSERT	BERR. COPPER	SILVER
TERM. SCRS.	STAIN. STEEL	
COVER	POLYESTER	
COV. SCR.	BRASS	NICKEL
COV. SPR.	STAIN. STEEL	
GASKET	RUBBER	
DISC	POLYCARBONATE	
ARM	POLYESTER	
HINGE PIN	STAIN. STEEL	
HINGE SPR.	STAIN. STEEL	
GLAND CAP	POLYESTER	
GLANDS	RUBBER	
CLAMPS	POLYESTER	
CLAMP NUTS	BRASS	NICKEL
ASS'Y SCRS	STAIN. STEEL	

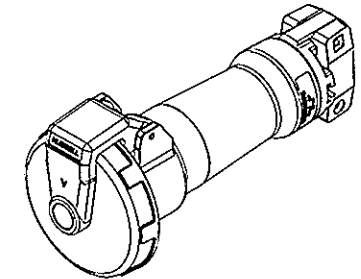

CATALOG NO. HBL430C9W  
(NOT SHOWN TO SCALE)

CAT NO.	CONFIGURATION	RATING	HOUSING		CAT. NO.	CONFIGURATION	RATING	HOUSING	
			COLOR	MATERIAL				COLOR	MATERIAL
					HBL430C7W		30A 3Ø 480VAC	RED	NYLON
HBL432C3W		32A-3h 380V-50HZ~ 440V-60HZ~	RED	NYLON	HBL430C9W		30A 3Ø 250VAC	BLUE	NYLON
HBL430C6V02		30A 380-415VAC	RED	VALOX	HBL430C9V04		30A 3Ø 250VAC	BLUE	VALOX
HBL430C5W		30A 3Ø 600VAC							
HBL432C6W		32AMP 380V-415VAC	RED	NYLON	HBL430C12W		30AMP 125/250VAC	ORANGE	NYLON

6	ADDED ISO VIEW TO INDICATE SOLID MODEL EMBEDDED IN DRAWING. PER DCN 21895 DDL	DJP	02/22/16
5	ADDED CAT. NO. HBL430C6V02 AND SPECS. TO TABLE. PER DCN 18867 DDL	CAC	05/30/12
SYM	REVISIONS	APP	DATE

THE DESIGN AND DIMENSIONS OF THE PRODUCT SHOWN ON THIS DRAWING ARE SUBJECT TO CHANGE WITHOUT NOTICE

TITLE  
30 & 32A. 3 POLE 4 WIRE  
PIN & SLEEVE CONNECTORS

TOLERANCES UNLESS OTHERWISE SPECIFIED .XX = ± .01 .XXX = ± .005 ANGLES = ± 2°	WIRING DEVICE-KELLEMS HUBBELL INCORPORATED SHELTON, CT	
	DR. BY MJK	APP. BY
	TR. BY	SCALE ---
	CHK'D BY	DATE 5-7-80